

JOREVS UVC-LED WATER DISINFECTION SYSTEM

Jorevs

Model: INUV-UWD-48LC

Important Notice

Please read manual before use.
Keep this manual in a safe and accessible
place for future reference.

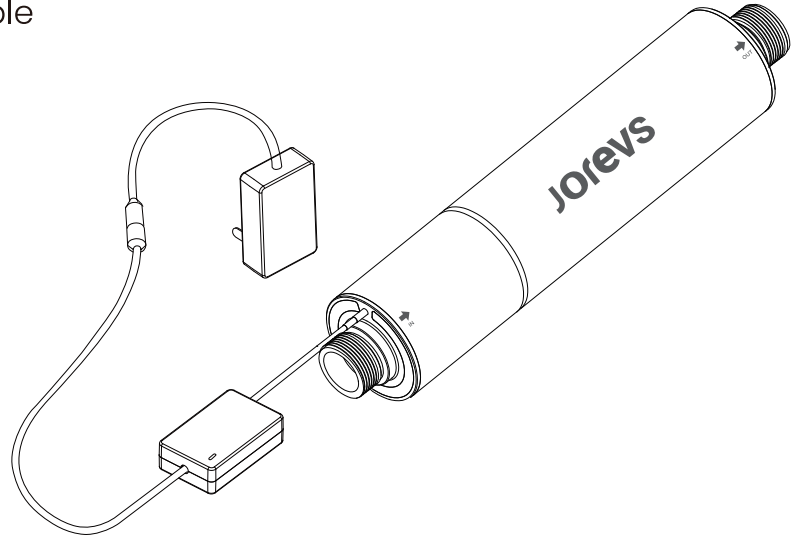

Designed by InstaUV LLC

Part A

Quick Start Guide

(1) PACKING LIST

No.	Product Name	Qty	Unit	Remark
1	UVC-LED Water Disinfection System	1	Unit	
2	24VDC 2.7A Power Supply Adapter	1	Unit	
3	3/4" NPT Male to 1" NPT Female Quick Connector	2	Unit	
4	Pipe Clamp	2	Unit	
5	Testing Report	1	Sheet	
6	Product Manual	1	Piece	
7	M8 Expansion Bolt	2	Unit	
8	Cleaning Brush	1	Unit	

(3) DIMENSIONS

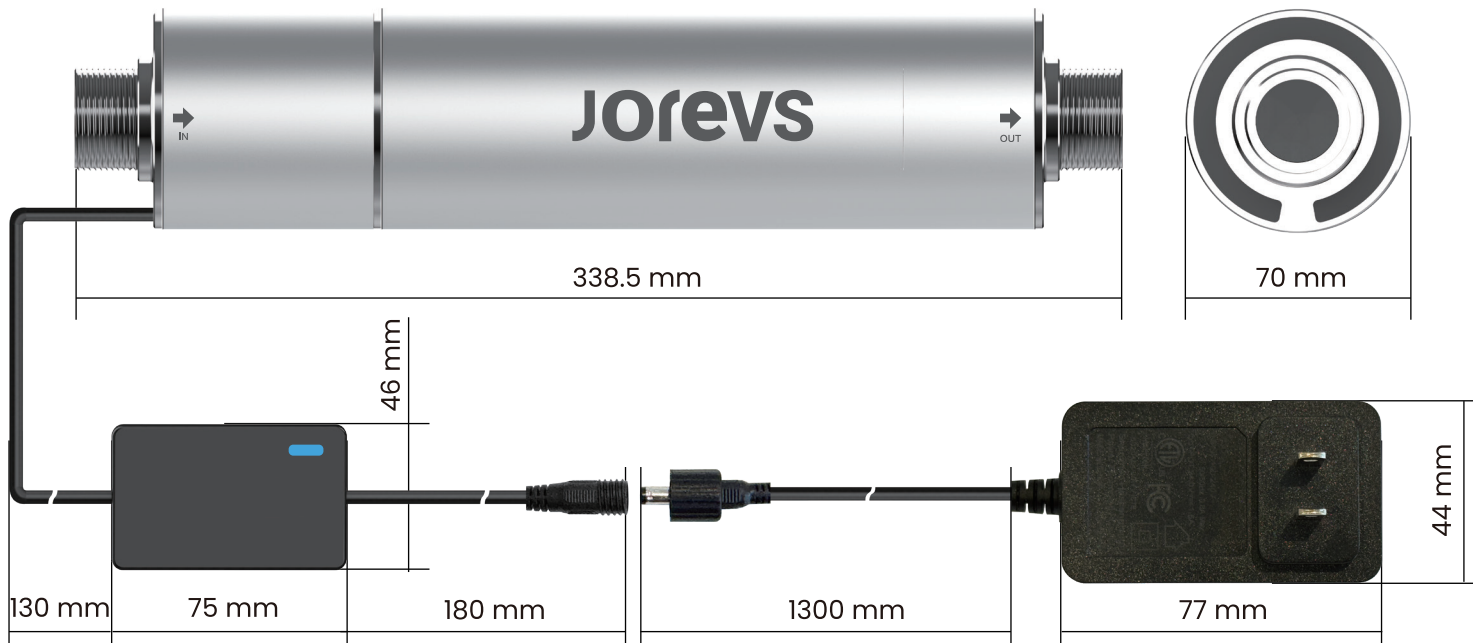

(4) INSTRUCTIONS FOR USE

1. Installation Guidelines:

General Requirements

- **Compliance:** Ensure all installation work complies with local plumbing, electrical, and building codes.
- **Location:** Install indoors in a dry, well-ventilated area. Protect the unit from freezing temperatures, direct sunlight, and weather exposure.
- **Orientation:** Mount horizontally or vertically on a **cold-water line** only.
- **Positioning:** Install as the final stage of filtration (after sediment filters, carbon filters, softeners, reverse osmosis systems, etc.) and as close to the point-of-use or point-of-entry as possible.

Plumbing & Water Pressure

- **Pre-Filtration:** A 5-micron sediment pre-filter is **mandatory** upstream to ensure effective UV transmittance.
- **Pressure Limits:**
 1. **Operating Range:** 14 – 116 psi (0.1 – 0.8 MPa).
 2. **Important:** If pressure exceeds 80 psi (0.55 MPa), it is mandatory to install a pressure-reducing valve (PRV) to prevent damage to internal components.
- **Leak Protection:** We recommend installing a drain pan plumbed to a floor drain beneath the unit to protect against potential leaks or condensation.

Electrical & Maintenance

- **Power:** Connect the adapter to a dedicated, GFCI-protected outlet. Keep cables away from sharp edges or heat sources.
- **Clearance:** Leave at least 20 inches (50 cm) of clearance at the rear of the unit to allow for future maintenance.

2. Start-Up & Operation

Initial Start-Up :

1. **Flush:** With power disconnected, turn on the water supply. Let water run for 2–3 minutes to flush out air and debris.
2. **Inspect:** Check all connections for leaks.
3. **Power On:** Plug in the adapter. The indicator light will turn Blue (Standby) or Green (Disinfecting) to confirm power.
4. **Final Rinse:** Run water for an additional 5 minutes before first use.

3.Operation Notes:

- **Instant Disinfection:** The unit is flow-activated and disinfects instantly without warm-up time. For longer storage, keep in a clean, closed container.
 - **Water Storage:** For optimal safety, consume treated water immediately. If storage is necessary, use a sanitized, closed container and consume within 4 hours.
- 4.Caution:** Install the unit in an area where potential leakage or condensation will not damage surrounding property. For high-value installations, we highly recommend using a monitored leak detector or an automatic shut-off valve.

5.Step-by-Step Installation Procedure:

Refer to Figure 1 for the typical whole-house layout and recommended ancillary components.

1.System Configuration and Bypass Assembly

- **Bypass Loop:** Install the system with a full bypass loop and isolation valves as shown in Figure 1. This allows you to isolate the unit for maintenance without interrupting the household water supply.

CRITICAL SAFETY NOTE:

- When the system is in bypass mode or powered off, water is **NOT** disinfected.
- If water use is necessary during service, use secondary disinfection (e.g., boiling or chlorination).
- Clearly label all faucets and the bypass valve with a visible tag: "**SYSTEM OFFLINE – DO NOT DRINK**" until the unit is back in normal operation.

2.Location and Orientation

- **Placement:** Select a dry, accessible indoor location protected from freezing and direct sunlight.
- **Clearance:** Ensure at least 50 cm (20 in) of clearance at the rear for future maintenance (chamber removal/cleaning).
- **Mounting:** The unit can be mounted horizontally (Figure 2A) or vertically with the inlet at the bottom (Figure 2B).

3.Mounting and Plumbing Connections

- **Secure Unit:** Mount the unit firmly to the wall using the supplied brackets/clamps.
- **Flow Restrictor:** If your model includes a flow restrictor, install it on the OUTLET port only. Ensure the arrow on the restrictor matches the water flow direction to prevent exceeding the rated flow.
- **IMPORTANT:** **Never solder fittings while they are attached to the unit.** Excessive heat will damage the internal O-rings and components. Solder connections first, let them cool, and then attach them to the unit.

4. Pressure Test for Leaks

- **Pressurize:** With power disconnected, slowly open the inlet isolation valve to fill the system with water.
- **Inspect:** Check all connections carefully for leaks.
- **If a leak occurs:**
 1. Shut off water and depressurize the system.
 2. Drain the chamber if necessary.
 3. Reseat the connection and hand-tighten securely.
 4. Repeat the test until the system is leak-free.

5. Electrical Connection and Power-Up

- **Connect Power:** Plug the adapter into a dedicated, GFCI-protected outlet.
- **Status Check:** The **BLUE** indicator should illuminate (Standby Mode). When water flows, the light should turn **GREEN**, indicating active UVC disinfection.

WARNING: Although the LEDs are enclosed, never look directly at the light source if the unit is open or disassembled. Intense UVC light can cause severe eye damage in seconds.

6. Final Flushing and Commissioning

- **Flush:** Open a downstream faucet and run water for at least **5 minutes**. This purges air, carbon fines, or any manufacturing residues from the chamber.
- **Verify:** Confirm that the indicator light turns a steady **GREEN** while water is flowing. The system is now ready for continuous service.

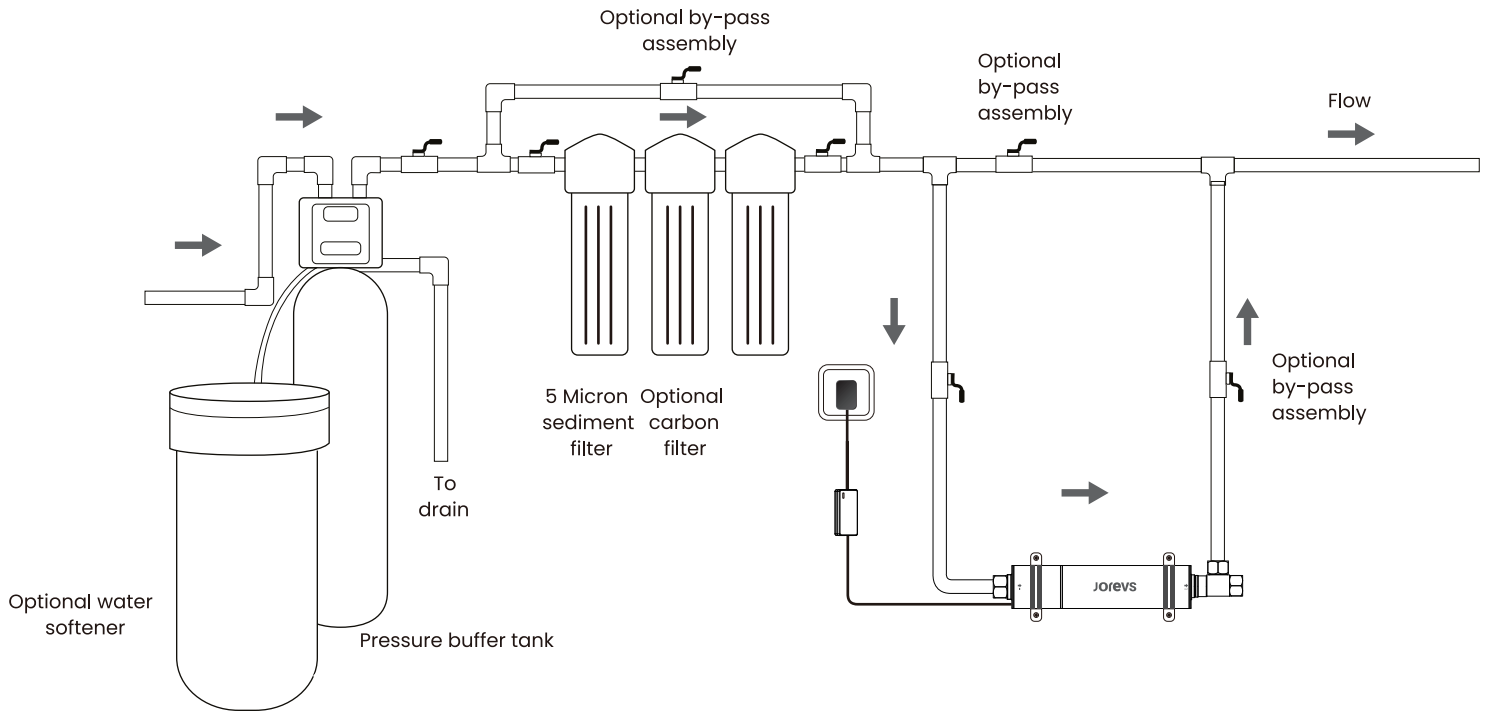
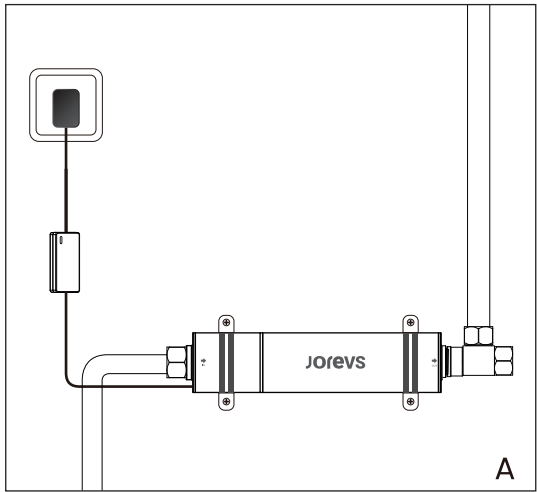
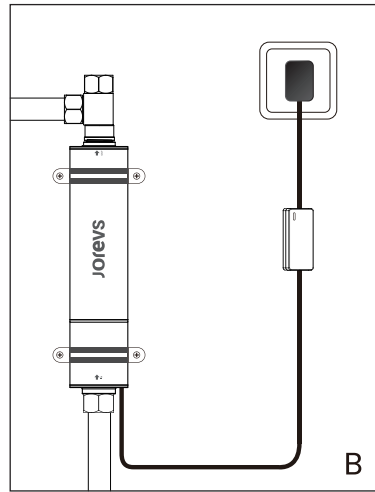

Figure 1 UV Treatment System



A



B

Figure 2 Installation - Vertical and Horizontal

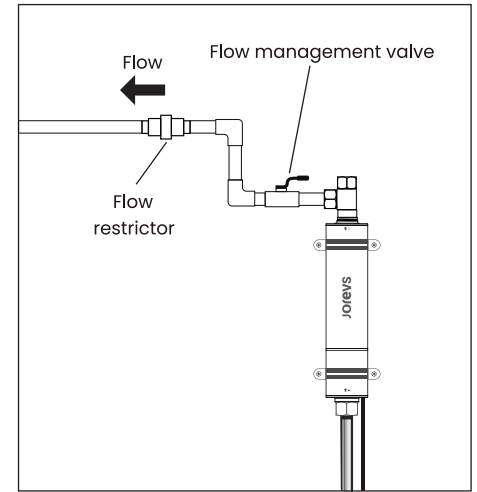

Figure 3 Flow Restrictor

Important:

Pre-filtration is Required.

See Part B for detailed water quality requirements.

Part B

User Manual & Technical Reference

Table of Contents

(1) Product Overview	1
(2) Product Features	1
(3) General Information	2
(4) Safety Information	3
(5) Product Parameters	6
(6) Maintenance	8
(7) Troubleshooting	13
(8) Manufacturer's Warranty	14
(9) Disclaimers	15

(1) PRODUCT OVERVIEW

Thank you for choosing the JOREVS UVC-LED Water Disinfection System — a cutting-edge, mercury-free, compact, and energy-efficient solution that delivers powerful, eco-friendly water purification with minimal maintenance and years of reliable performance. Utilizing the latest UVC-LED technology, it emits highly effective UVC light in the optimal 270–280 nm wavelength range to instantly disrupt the DNA and RNA of bacteria, viruses, and other microorganisms as water flows through, rendering them harmless and ensuring safe, clean water for consumption. Ideal for drinking water purification, whole-house or point-of-use domestic systems, aquariums, food and beverage processing, laboratories, and more — enjoy superior protection and peace of mind with this advanced, environmentally responsible disinfection system.

(2) PRODUCT FEATURES

- **99.999% Disinfection Efficacy Against E.Coli:** Delivers laboratory-certified log-5 reduction of bacteria such as E.Coli by irreversibly damaging microbial DNA and RNA True Broad-Spectrum Protection: Highly effective against a wide range of waterborne pathogens, including chlorine-resistant parasites (e.g., Cryptosporidium and Giardia), viruses, and bacteria.
- **100% Chemical-Free:** Pure physical disinfection process leaves no taste, odor, or harmful byproducts — completely safe for drinking water, and the environment.
- **Mercury-Free & Environmentally Responsible:** Unlike traditional mercury UV lamps, UVC-LED technology contains no toxic mercury, eliminating contamination risk if damaged and allowing worry-free disposal or recycling.
- **Instant Full-Power Disinfection:** Turns on and reaches 100% intensity in microseconds — no warm-up time required.
- **Energy-Saving Intelligent Operation:** Activates only when water flows (thanks to the integrated flow sensor) and switches off instantly when flow stops — consumes zero power in standby, adds no heat to stored water, eliminates the need for pressure/temperature relief valves caused by heat buildup, and dramatically reduces electricity costs compared to always-on mercury UV systems.
- **Exceptional Lifespan >15,000 Hours:** UVC-LED modules last 10× longer than conventional mercury lamps, dramatically reducing replacement frequency and long-term operating costs.
- **Temperature-Independent Performance:** Maintains consistent, high-output disinfection even in cold or hot water conditions (0–60°C) — unlike mercury lamps that lose effectiveness in low temperatures.
- **Zero UV Leakage Safety:** Fully sealed optical chamber with advanced light-trapping design ensures no harmful UVC radiation escapes, protecting users and allowing safe installation in homes and appliances.

(3) GENERAL INFORMATION

- **Indoor Use Only:** This UV water purifier is designed exclusively for indoor installation. Protect it from direct exposure to extreme weather and freezing conditions. Maintain ambient temperature between 36°F–104°F (2°C–40°C).
- **Electrical Requirements:** Supply voltage and frequency must exactly match the specifications on the unit's label. Connection to a dedicated GFCI-protected outlet is mandatory. If no GFCI outlet is present, a qualified electrician must install one in full compliance with local electrical codes. Use of a quality surge protector is strongly recommended.
- **Location and Accessibility:** Install the unit in a dry, well-lit, and easily accessible area. Allow a minimum clearance of one chamber length beyond the quartz tube sleeve end to facilitate routine cleaning .
- **Point-of-Entry Positioning:** For maximum microbiological protection, install the UV system as the final treatment stage, immediately before the point of entry and after all other water treatment equipment (e.g., softeners, carbon filters, reverse osmosis systems, pressure tanks, pumps, etc.).
- **Supervision and Restricted Use:** This device is not a toy and must not be operated or handled by children. Individuals with reduced physical, sensory, or mental capabilities, or lacking experience with the equipment, may only use it under direct supervision or after receiving proper instruction.
- **Compliance and Professional Installation:** All plumbing, electrical, and installation work must fully comply with local building, plumbing, electrical, and sanitation codes. Consult your local public works or building department for applicable regulations.
- **Pre-Operation Requirement:** Thoroughly read and understand this entire manual before installing, operating, or performing any maintenance on the system.

(4) SAFETY INFORMATION

- Before installing or operating the JOREVS UVC-LED Water Disinfection System, carefully read this entire manual. Pay close attention to all DANGER, WARNING, and CAUTION statements. Failure to follow these instructions may result in serious personal injury or death, or cause damage to the equipment.
- Do not use or install this system in any manner other than that explicitly described in this manual, as doing so may impair its safety features and void the warranty. The protective measures incorporated in this equipment must not be bypassed or compromised.

1.1 Safety Instructions:

DANGER: Indicates an imminently hazardous situation which, if not avoided, will result in death or serious injury.

- **Risk of Fatal Electric Shock:** Water is present near electrical components. To prevent electric shock or electrocution.
- Never operate the system if the power cord or plug is damaged, frayed, or cracked.
- Do not handle the plug or system with wet hands.
- Immediately discontinue use if the system is malfunctioning, has been dropped, or shows any signs of damage.
- Do not attempt any repairs yourself — contact only an authorized service technician for all servicing.
- **Improper Use:** This system is certified only for the disinfection of microbiologically safe, clear potable water. Using it on water of unknown quality or for non-potable applications may result in illness or death.
- **Freezing Conditions:** Do not install or operate where the system may be exposed to outdoor weather or temperatures below 32°F (0°C) unless all water has been completely drained and the supply lines disconnected.

WARNING: Indicates a potentially hazardous situation which, if not avoided, could result in death or serious injury.

- Unapproved modifications or attachments not expressly recommended or supplied by the manufacturer may create unsafe conditions and will void the warranty.
- Always unplug the system by grasping the plug firmly — never pull on the cord itself.
- If the power cord becomes damaged, it must be replaced only by the manufacturer, its authorized service agent, or a similarly qualified person.
- **Extension Cords (when permitted):** Use only a 3-wire, grounded extension cord rated for outdoor use (if applicable) with an electrical rating equal to or greater than the system's rating. Inspect the cord for damage before each use, route it to avoid tripping hazards, and keep it away from heat, sharp edges, and water. Disconnect the extension cord from the power source before disconnecting it from the system.

CAUTION: Indicates a potentially hazardous situation which, if not avoided, may result in minor or moderate injury or equipment damage.

- After installation, carefully inspect the system before applying power. Do not energize if water is present on any electrical components (controller, lamp connector, etc.).

NOTICE: Important operating and maintenance information.

- This system is designed for permanent connection to the water supply and metallic plumbing. Proper grounding through the building’s electrical system and plumbing is required.
- This system is not intended for installation in or above water, in swimming pools, spas, or any location where persons may be immersed while the unit is operating.

1.2 Water Chemistry

- Pre-Filtration Requirement and Optimal Water Quality
- Pre-filtration is mandatory for the proper operation and long-term performance of the JOREVS UVC-LED Water Disinfection System. UVC-LED technology relies on high UV transmittance (UVT) to effectively reach and inactivate microorganisms. Suspended particles, sediment, organic matter, iron, manganese, hardness scale, or tannins in the feed water will absorb or scatter UVC light, dramatically reducing disinfection efficiency, and potentially allowing pathogens to survive.
- A suitable pre-filtration system (typically a 5-micron sediment filter, followed by any additional treatment required for iron, hardness, organics, or tannins) must be installed upstream of the JOREVS unit at all times. Failure to provide adequate pre-treatment will impair UV performance and may void the product warranty.
- To achieve optimal UV transmittance, reliable microbiological protection, and maximum system longevity, always treat the water to the parameters listed in the following section before it enters the UVC-LED chamber.

Water Quality and Minerals	Level
Turbidity	< 1 NTU
Iron	< 0.3 ppm (0.3 mg/L)
Hardness*	< 7 gpg (120 mg/L)
Manganese	< 0.05 ppm (0.05 mg/L)
Tannins	< 0.1 ppm (0.1 mg/L)
UV Transmittance	> 75% (call factory for recommendations on applications where UVT < 75%)

* Water Hardness and Pre-Treatment Guidelines

- When total hardness is less than 7 grains per gallon (120 mg/L or 7 gpg), the JOREVS UVC-LED Water Disinfection System will deliver optimal performance, provided the quartz water flow channel (optical window) is cleaned according to the recommended maintenance schedule.
- When total hardness exceeds 7 gpg (120 mg/L), a water softener or effective scale-inhibition device must be installed upstream to prevent mineral buildup on the optical surfaces inside the quartz water flow channel, which would otherwise reduce UV transmittance and compromise disinfection efficacy.

- If any water quality parameter (e.g., iron, manganese, tannins, turbidity, or hardness) exceeds the limits outlined in the Water Quality Requirements table, appropriate pre-treatment equipment must be installed and maintained prior to the UV chamber.
- Failure to manage excessive hardness or other out-of-spec conditions will diminish disinfection performance, accelerate fouling of the optical components, reduce LED lifespan, and may void the manufacturer's warranty.
- Professional water testing by an authorized dealer or certified laboratory is strongly recommended before installation to confirm compliance and determine the necessary pre-treatment. Proper water conditioning is critical to achieving reliable, long-term microbiological protection.

(5) PRODUCT PARAMETERS

No.	Specifications	
1	Model	INUV-UWD-48LC
2	Rated Flow Rate	12 GPM
3	Water Pressure	0.1 to 0.8 MPa (14 to 116 psi); Absolute Maximum 0.86 MPa (125 psi)
4	Water Pipe Fitting	1"
5	Power Adapter Input	100-240 V 50/60 Hz
6	Power Adapter Output	24 V, 2.7 A
7	UVC-LED Lifespan When Continuously On	3 years (15,000 hours-continuous use)
8	Exterior Material	Aluminum
9	Target Microorganisms	E. coli, among others
10	Disinfection Efficiency	(*) Up to 99.999% or 5.0 Log
11	Operating Temperature	5°C to 40°C (do not allow water to freeze inside the device which can result in permanent damage to the product)

Performance Disclaimer

The stated disinfection efficacy (up to 99.999% reduction) is achieved under controlled laboratory conditions and may vary depending on actual water quality, flow rate, UV transmittance, and other site-specific factors. These results are provided for reference only and do not constitute a performance guarantee in real-world applications.

Test conditions: Independent laboratory testing conducted using Escherichia coli (ATCC 8099) as the challenge organism at inlet concentrations of 5×10^6 to 5×10^7 CFU/mL in clear, dechlorinated, sterile water with UV transmittance >95% at 275 nm. Actual field performance should be validated through periodic microbiological testing of treated water.

pH	7.5+0.5	turbidity	< 1.0 NTU	TDS	200 to 500 mg/L
UV transmittance	98+2%	temperature	20+2.5°C(68±5 °F)		

Recommended Operational Conditions

Parameter	Value	Unit
Power Adapter Input	110	Volt(AC)
Flow Rate	45.4(12)	LPM(GPM)
Water Pressure	0.1 ~ 0.8	MPa
Water Temperature	25(77)	°C(F)
Ambient Temperature	25(77)	°C(F)

Recommended Water Quality: Use with pre-filtered water. Do not use unfiltered liquids such as river, lake, or groundwater.

Maximum Ratings

Parameter	Min	Max	Unit
Operating Pressure	1(14.5)	8(116.03)	bar (psi)
Water Temperature	0(32)	80(176)	°C(F)
Ambient Temperature	4(39.2)	60(140)	°C(F)

Operating the device outside these conditions may cause permanent damage.

Note: Do not allow water to freeze inside the device – risk of rupture.

Regulation/Guideline	Status
CE (EMC: 2014/30/EU Electromagnetic Compatibility Directive; LVD: 2014/35/Eu Low Voltage Directive)	Certified
ROHS2.0(RoHS 2.0 Directive 2011/65/EU Annex II (EU) 2015/863 as last amended by Directive (EU) 2017/2102.)	Compliant
REACH (EC No.1907/2006)	Compliant
ISO 9001:2015	Certified
Halogens(Fluorine, Chlorine, Bromine, Iodine)Content – IEC/EN61249-2-21:2003)	Compliant

(6) MAINTENANCE

Maintenance and Servicing Warnings

WARNING:

- Failure to follow these instructions could result in serious injury, electric shock, or system damage.
- Always disconnect electrical power at the outlet or adapter before performing any maintenance, cleaning, or servicing on the system.
- Always shut off the water supply and fully release system pressure (by opening a downstream faucet) before disassembling any part of the unit.
- Regularly (at least monthly) inspect the system to confirm the blue power indicator is illuminated and no alarm conditions are present.
- If the system will be exposed to freezing temperatures (e.g., seasonal home closure or vacation), always drain the chamber completely and disconnect power to prevent damage from ice expansion.

Quartz Water Flow Channel Cleaning:

- **NOTES:** Even with proper pre-filtration, dissolved minerals in the water can gradually deposit on the inner surface of the quartz water flow channel, reducing UV transmittance and disinfection performance. Periodic cleaning is essential to maintain full effectiveness.

Recommended Cleaning Interval:

- Biennially, or Immediately if reduced flow, alarm activation, or visible fouling is observed — whichever comes first.

Cleaning Procedure Without The Optional Maintenance Kit:

1.Preparation

- Disconnect the power adapter from the electrical outlet.
- Shut off the main water supply valve and release residual pressure by opening a downstream faucet until water flow stops.

2.Access the Quartz Flow Channel

- Completely remove the unit from its mounting position (ensure adequate rear clearance as noted during installation).
- Carefully detach the rear end (water outlet side) to access the quartz flow channel.

3.Cleaning

- Use only the JOREVS-approved cleaning brush with a mild scale-removal solution (e.g., white vinegar).
- Insert from the rear end (water outlet side) and gently scrub the inner quartz surface to remove any mineral deposits.
- Rinse thoroughly with clean water until no cleaning residue remains.

4.Reassembly and Commissioning

- Reinstall the front (inlet) and rear (outlet) securely, ensuring proper seal.
- Remount the unit, restore water supply, and check for leaks.
- Reconnect power and verify normal operation (blue indicator illuminated).
- Flush the system for at least 5 minutes before resuming normal use.

CAUTION: Never use abrasive materials, harsh chemicals, or sharp objects that could scratch the quartz surface – scratches permanently reduce UV transmission. Wear protective gloves and eyewear when handling cleaning solutions.

Cleaning Steps:

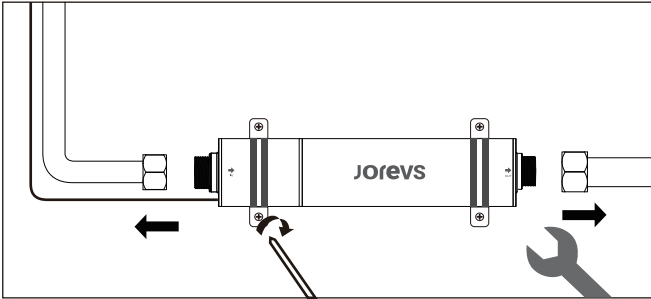

Step 1 : Remove the pipelines and module clamp screws at the water inlet and outlet.

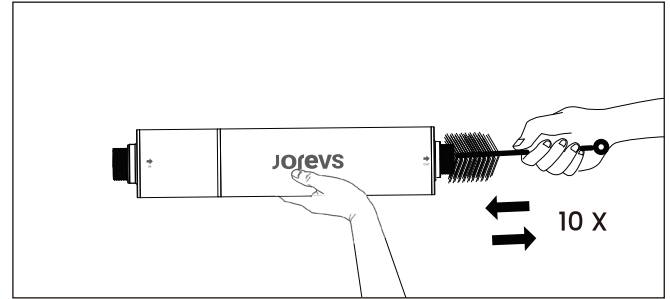

Step 2 : Insert the cleaning brush into the JOREVS module to clean the quartz tube inside, about 10 round trip scrubs.

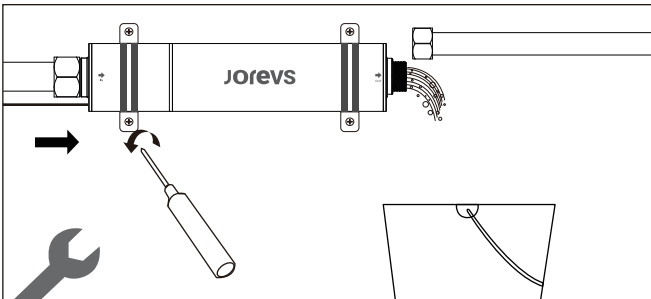

Step 3 : Connect the inlet front end and Open slightly the inlet side water valve to rinse the scale on the quartz tube wall.

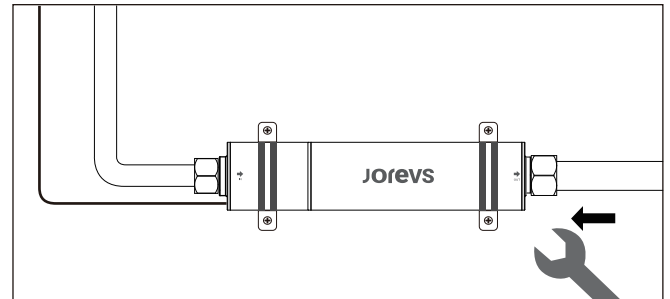

Step 4 : Rotate and tighten the outlet rear end.

Cleaning Procedure With The Optional Maintenance Kit:

1.Preparation

- Disconnect the power adapter from the electrical outlet.
- Shut off the main water supply valve and release residual pressure by opening a downstream faucet until water flow stops.

2.Access the Quartz Flow Channel

- Completely remove rear cover from its mounting position to access the outlet part of the add-on three way connector unit to access the quartz water flow channel.

3.Cleaning

- Use only the JOREVS-approved cleaning brush with a mild scale-removal solution (e.g., white vinegar).
- Gently insert and scrub the inner quartz surface to remove any mineral deposits.
- Rinse thoroughly with clean water until no cleaning residue remains.

4.Reassembly and Commissioning

- Reinstall the rear cover back to its mounting position , ensuring proper seal.
- Restore water supply, and check for leaks.
- Reconnect power and verify normal operation (blue indicator illuminated).
- Flush the system for at least 5 minutes before resuming normal use.

CAUTION: Never use non-authorized, or abrasive materials, harsh chemicals, or sharp objects that could scratch the quartz surface — scratches permanently reduce UV transmission. Wear protective gloves and eyewear when handling cleaning solutions.

Cleaning Steps:

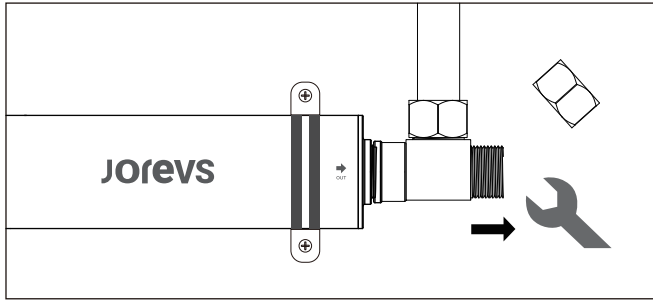

Step 1 : Rotate to open the hex nut.

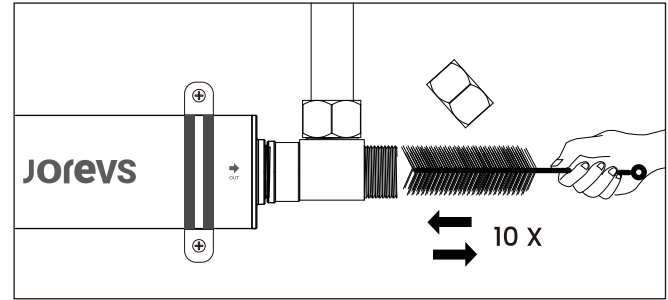

Step 2 : Insert the cleaning brush into the JOREVS module to clean the quartz tube inside, about 10 round trip scrubs.

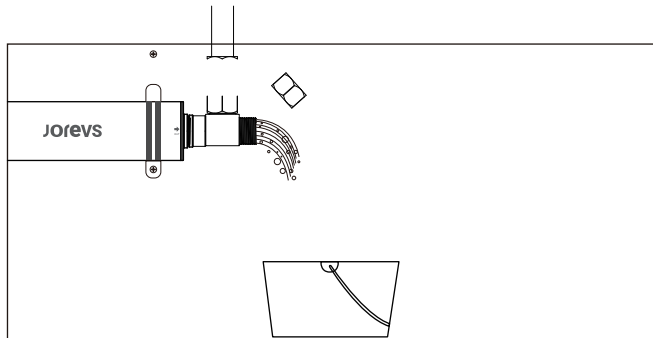

Step 3 : Open slightly the water valve to rinse the scale on the quartz tube wall. (Catch the flushing water with a container.)

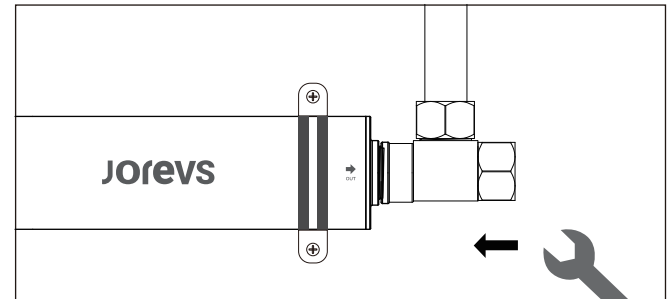

Step 4 : Rotate and tighten the hex nut.

(7)**TROUBLESHOOTING**

Symptom	Possible Cause	Possible Solution(s)
Pressure Drop	Sediment pre-filter clogged	Replace filter cartridge with appropriate 5 micron cartridge. Note: Check source water supply as fluctuations may occur in source pressure.
	Flow regulator	Flow regulator will result in pressure drop when approaching full flow.
High Bacteria Counts	Quartz water flow tube is stained or dirty	Quartz tube is stained or dirty. Clean sleeve with scale cleaner and eliminate source of staining problem (e.g.,soften hard water).
	Change in feed water quality	Have source water tested to ensure that water quality is still within allowable limits for this system.
	Contamination in water lines after UV system	UV system must have a bacterial free distribution system to work effectively.
	Possible break-through of sediment through pre-filter	Have source water tested for turbidity - may need stepped filtration in order to catch all sediment entering water system (20 micron filter followed by a 5 micron filter followed by UV system).
Water Appears Milky	Caused by air in the water lines	Run water until air is purged.
Unit Leaking Water	Problem with seal	Check for cuts or abrasions, clean connecting points, moisten with water/ lubricant and re-install.
	Condensation on chamber caused by excessive humidity & cold water	Check location of UV system and control humidity.
	Inadequate inlet/outlet port connections	Check thread connections, reseal with Teflon® tape and re-tighten.
System Shutting Down Intermittently	Interrupted controller	Ensure system has been installed on its own circuit, as other equipment may be drawing power away from UV (ie. pump or fridge). UV system should not be installed on a circuit which is incorporated into a light switch.

(8) MANUFACTURER'S WARRANTY

Our Commitment to You

- At JOREVS, we are dedicated to delivering exceptional products and support that surpass your expectations. Your JOREVS UVC-LED Water Disinfection System is crafted to the highest standards of quality and reliability, reflecting our commitment to your satisfaction as a valued customer. For any questions, troubleshooting, or assistance with your system, our Technical Support team is here to help. Please reach out via email at support@instauv.com — we respond promptly and aim to resolve your concerns efficiently.

Specific Warranty Coverage

- Warranty terms apply exclusively to JOREVS UVC-LED Water Disinfection Systems and are subject to the General Conditions and Limitations below. Coverage begins from the original purchase date.
- JOREVS warrants the UV chamber against defects in materials and workmanship for **five (5) years**. During this period, we will repair or replace (at our discretion) any defective chamber at no cost to you. Return the defective part to your dealer for processing.
- One-Year Limited Warranty on Electrical and Hardware Components.
- JOREVS warrants the electrical components (e.g., controller, power adapter) and hardware (e.g., seals, fittings) against defects in materials and workmanship for one (1) year. During this period, we will repair or replace (at our discretion) any defective covered parts at no cost to you. Return the defective part to your dealer for processing.

General Conditions and Limitations

- **These warranties do not cover:** Damage from misuse, improper installation or maintenance, accidents, natural disasters, acts of God, or cosmetic imperfections (e.g., minor scratches) that do not affect functionality. Coverage is void if the system was used in conditions that deviate from the Owner's Manual instructions.
- Repaired or replaced parts are warranted only until the original warranty period expires for that component. Shipping and handling costs for returned items are the customer's responsibility.
- **Exclusive Remedy:** These limited warranties represent the sole remedy for any product defect or failure, regardless of the legal basis (e.g., contract, negligence, strict liability). No other warranties — express, implied, oral, written, or statutory — apply, including merchantability or fitness for a particular purpose.
- **Limitation of Liability:** JOREVS is not liable for personal injury, property damage, or any special, incidental, indirect, or consequential damages arising from product use or misuse. Our total liability is limited to repair or replacement of the defective product/part, and ends upon warranty expiration.

For full warranty details or to register your product, please contact support. Thank you for choosing JOREVS — clean, safe water starts here.

(9) DISCLAIMERS

Important Disclaimers and Safety Summary

Please read carefully. By installing this product, you agree to the following terms:

1. Intended Use :

This system is designed **only** for disinfecting visually clear, pre-filtered water. It is **not** intended to turn wastewater or sewage into potable water.

2. Installation Liability :

Installation must comply with local plumbing and electrical codes. JOREVS is not liable for water leaks, property damage, or personal injury resulting from improper installation, DIY modifications, or failure to install a leak detector/pressure regulator where required.

3. Water Quality:

Disinfection efficacy depends on incoming water quality. Users are responsible for ensuring pre-filtration (removing sediment, iron, hardness) to maintain performance.

4. No Guarantee of Health Protection:

While JOREVS systems are tested for high disinfection efficacy, we **do not guarantee** the prevention of all illness or infection. Efficacy depends heavily on incoming water quality, flow rate, and proper maintenance. Users are responsible for validating water quality through independent testing.

5. UVC Safety: WARNING:

This device emits high-intensity UVC light. **NEVER** look directly at the light source or expose skin to the light. Severe eye or skin damage can occur instantly.

6. Limitation of Liability:

JOREVS's total liability is limited to the repair or replacement of the defective product. We are not liable for any incidental, consequential, or indirect damages arising from the use of this product.

7. User Acknowledgment & Indemnity:

By purchasing and using this system, you acknowledge that you have read and understood these warnings. You agree to hold JOREVS and its affiliates harmless from any claims, liabilities, or losses arising from misuse, non-compliance with the manual, or unauthorized modifications.

Jorevs